

Finding the volume of a three dimensional object



National Center and State Collaborative

The contents of this product were developed under a grant from the Department of Education (PR/Award #: H373X100002, Project Officer, Susan.Weigert@Ed.gov). However, the contents do not necessarily represent the policy of the Department of Education and no assumption of endorsement by the Federal government should be made.

What is volume

- Volume is the amount of space a 3 dimensional object occupies.
- Volume can be determined by filling an object with unit cubes **OR** by using the formula

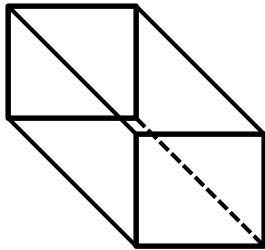

$$V = l \times w \times h$$

length width height

Helpful Hint:
Don't forget to review
that the units for
volume are cubed

Finding volume: An example

- Using the graphic on the right, determine the volume for the rectangular object

- Step 1: $V = 10 \times 5 \times 4$
length width

- Step 2: $V = 200 \text{ cm}^3$
Don't forget the units

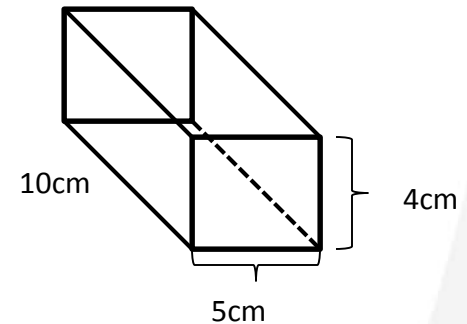

← height

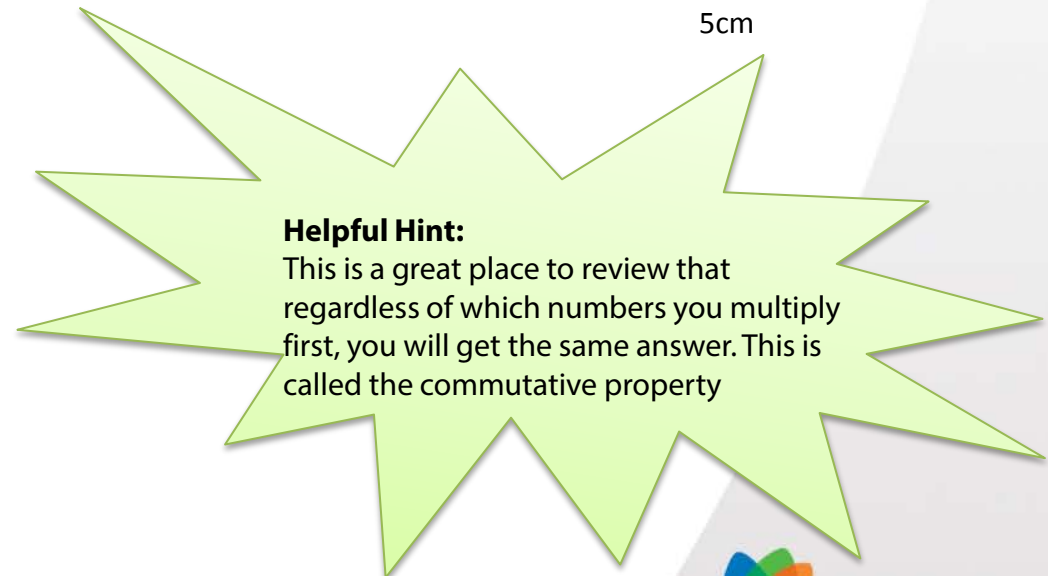

Helpful Hint:

This is a great place to review that regardless of which numbers you multiply first, you will get the same answer. This is called the commutative property

Compare the two

- Compare the results from both methods to demonstrate how both methods were used to find the volume of the same shape.
- Ideas for increasing difficulty during instruction:
 - Give students the volume and have them manipulate the formula to determine the length, width, or height of an object
 - Provide real-world word problems and require students to solve the equation and pull out the facts necessary to find the solution

Making Connections

- Find the volume of an object addresses the following 5th and 6th grade Core Content Connectors:
 - 5-6.NO.3a1 Justify the use of a strategy, rule, or identified characteristic to solve a given problem
 - 5.ME.2b2 Apply formula to solve one step problems involving volume
 - 5.ME.1d4 Use filling and multiplication to determine volume
 - 6.ME.1a2 Identify the appropriate formula to use when measuring for different purposes in a real life context
 - 6.ME.1c1 Find the area of a 2-dimensional figure and the volume of a 3-dimensional figure